

GB 2211573
JUL 1959

(12) UK Patent Application (19) GB (11) 2 211 573 (13) A

(43) Date of A publication 05.07.1989

<p>(21) Application No 8725337.3</p> <p>(22) Date of filing 29.10.1987</p>	<p>(51) INT CL[*] F16L 41/08</p> <p>(52) UK CL (Edition J) F2G G2A G29 G9H G9Y</p> <p>(56) Documents cited None</p> <p>(58) Field of search UK CL (Edition J) F2G INT CL[*] F16L</p>
<p>(71) Applicant Usui Kokusai Sangyo Kabushiki Kaisha, (Incorporated in Japan) 131-2 Nagasawa, Shimizu-cho, Sunto-gun, Shizuoka Prefecture, Japan</p> <p>(72) Inventor Kazumasa Umehara</p> <p>(74) Agent and/or Address for Service Withers & Rogers, 4 Dyer's Buildings, Holborn, London, EC1N 2JT, United Kingdom</p>	

(54) Fixing pipe to flange

(57) Planar flange 1 has a mounting hole formed through it having portions formed of different diameters 1', 3 the wider portion receiving an annular resilient sealing member 4. The pipe P has a radially expanding annular portion P* engaged with the peripheral edge 1' of the mounting hole. Within the mounting hole, the end 5 of the pipe is enlarged or a part of the pipe-diameter portion is radially expanded to press the resilient sealing member 4 and to clamp the radially inwardly projecting peripheral edge 1' of the mounting hole between the radially expanded portion P* and the enlarged end or radially expanded end portion 5, thereby fixedly connecting the flange and the pipe.

Fig. 1

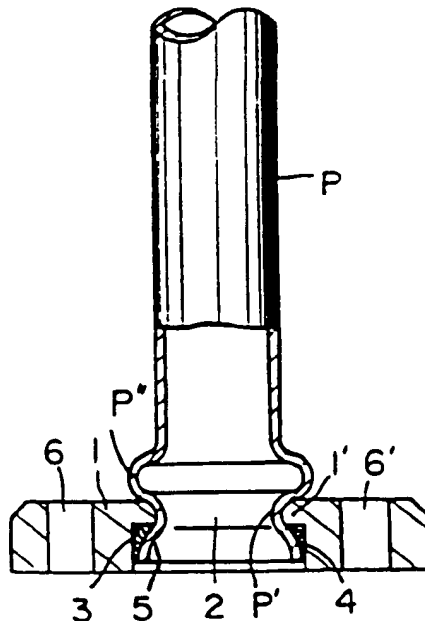

2211573

TITLE OF THE INVENTION

ARRANGEMENT FOR FIXING END OF THIN-WALLED PIPE TO FLANGE
COUPLING

BACKGROUND OF THE INVENTION

Field of the Invention

The present invention relates generally to an improved arrangement for fixedly connecting a flange coupling and an end of a thin-walled metal pipe of the type which has a relatively small diameter of approximately 50 mm or less and a wall thickness of approximately 2 mm or less and which is typically employed in an automobile, various kinds of machines and equipment in the form of a supply pipe through which oil or air is supplied.

Description of the Prior Art

Referring to Fig. 3 showing a prior art arrangement of this kind, a planar flange 11 has an mounting hole 12 formed through an axial portion thereof, and an end P_1 of a pipe P_1 is inserted into the mounting hole 12. In this state, the flange 11 is fixed to the pipe P_1 by heat brazing, as at 13, using a brazing metal material such as copper or brass.

Typically, the thickness of the flange 11 remarkably differs from that of the pipe P_1 . Therefore, in the prior art fixing arrangement, a deterioration may occur in the mechanical properties of the brazed portion 13 of the pipe P_1 due to localized overheating which may be caused, as by an

inexperienced operator during a heat brazing operation employing a burner or the like. This deterioration may cause the formation of a crack or a breakage in combination with vibration applied to a piping including the pipe P_1 while it is being used. Also, the brazing material may run on a mounting sheet surface of the flange 11 by brazing heat. In addition, since the entire surface of a product is subjected to anti-corrosive plating after the aforesaid brazing operation, there is a problem in that the quality of corrosive resistance may deteriorate.

SUMMARY OF THE INVENTION

It is therefore an object of the present invention to provide an improved fixing arrangement including a flange having a mounting hole provided with an radially enlarged portion in which a resilient sealing member is inserted and a pipe having an end portion provided with an radially expanded portion, the end portion being inserted into the mounting hole such that the radially expanded portion is engaged with the back of the flange. In addition, the end of the pipe is enlarged or a portion of the end portion of the pipe is radially expanded to press the resilient sealing member and to clamp a radially inwardly projecting peripheral edge of the mounting hole between the radially expanded portion and the enlarged end or radially expanded end portion, thereby fixedly connecting the flange and the pipe. This eliminates

the previously-described heat brazing and prevents a crack or breakage from being formed by a deterioration in the mechanical properties of the fixed portion of the pipe as well as various troubles from occurring due to a brazing material running on the mounting sheet surface of the flange by brazing heat. In addition, it is possible to use previously-plated flange and pipe, thereby remarkably improving the efficiency of fixing operation.

To this end, the present invention provides an improved fixing arrangement for fixedly connecting one end of a thin-walled metal pipe and a flange coupling. The improved fixing arrangement includes a planar flange having a mounting hole formed through an axial portion thereof, a radially expanded portion being formed in a portion of the peripheral surface of the mounting hole for receiving an annular resilient sealing member; and a pipe having one end provided with a pipe-diameter portion and a radially expanding annular portion. The radially expanding annular portion is engaged with the peripheral edge of the mounting hole on the back side of the flange to insert the pipe-diameter portion into the mounting hole. In addition, within the mounting hole, the end of the pipe-diameter portion is enlarged or a part of the pipe-diameter portion is radially expanded to press the resilient sealing member and to clamp the radially inwardly projecting peripheral edge of the mounting hole

between the radially expanded portion and the enlarged end or radially expanded end portion, thereby fixedly connecting the flange and the pipe. The radially expanded portion may be formed in a groove-like or step-like shape.

Further objects, features and advantages of the present invention will become apparent from the following description of preferred embodiments of the present invention with reference to the accompanying drawings.

BRIEF DESCRIPTION OF THE DRAWINGS

Fig. 1 is a partially cutaway, plan view of a first preferred embodiment of the present invention showing an arrangement for fixing one end of a thin-walled metal pipe to a flange coupling;

Fig. 2 is a view similar to Fig. 1 showing a second preferred embodiment of the present invention; and

Fig. 3 is a partially cutaway, plan view of a prior art fixing arrangement.

DESCRIPTION OF THE PREFERRED EMBODIMENT

Preferred embodiments of the present invention will be described below with reference to Figs. 1 and 2. Fig. 1 is a partially cutaway, plan view of a first preferred embodiment of the present invention showing an arrangement for fixing one end of a thin-walled metal pipe to a flange coupling and Fig. 2 is a view similar to Fig. 1 showing a second preferred embodiment of the present invention.

reference numerals 6 and 6' respectively denote holes receiving bolts secured to a base (not shown).

It is to be noted that the radially expanded portion 3 may be formed in the peripheral surface of the mounting hole 2 in a stepped shape (Fig. 1) or in a groove-like shape (Fig. 2).

In accordance with the present invention including the above-described arrangement, the pipe-diameter portion P' of the end portion of the pipe P is fitted into the mounting hole 2 having the radially expanded portion 3 in which the resilient sealing member 4 is fitted, and the pipe-diameter portion P' is enlarged at its end or a part of the same is radially expanded to press the resilient sealing member 4 against the wall of the radially expanded portion 3. In addition, the radially inwardly peripheral edge 1' of the mounting hole 2 is clamped between the radially expanded portion 3 and the enlarged end or radially expanded portion, thereby airtightly and firmly fixing the pipe P to the flange 1.

As described above, in the arrangement for fixing a thin-walled metal pipe to a flange coupling in accordance with the present invention, the pipe P is fixedly connected to the flange 1 by a pressure applied to the resilient sealing member 4 by the radially outwardly expanded portion 3 and by a clamping force acting upon the radially inwardly

projecting peripheral edge 1' of the mounting hole 2 between the annularly expanded portion P" and the radially enlarged end or the radially expanded portion 5. Therefore, it is possible to eliminate a fixed portion which is heat-brazed, and this prevents various troubles from occurring on the mounting sheet surface of the flange 1 due to the formation of a crack, breakage or flowing of a brazing material owing to a deterioration in the mechanical properties of the fixed portion of the pipe P. In addition, the flange 1 and the pipe P which are previously plated may be used so that the efficiency of a mounting operation may be improved, thereby achieving a remarkably useful arrangement for fixing an end of a thin-walled metal pipe to a flange coupling.

While this invention has been described in conjunction with specific embodiments thereof, it is evident that many alternatives, modifications and variations will be apparent to those skilled in the art. Accordingly, it is intended to embrace all such alternatives, modifications and variations as fall within the spirit and broad scope of the appended claims.

CLAIMS

1. An arrangement in which a pipe is attached to a flange having a mounting hole receiving the pipe and the periphery of which has a radially inwardly directed projection, the pipe being expanded for abutment with one
5 side of the projection, and secured by fixing means expanding radially to press a resilient sealing member against the other side of the projection.
2. An arrangement for fixedly connecting an end of a thin-walled metal pipe to a flange coupling comprising:
10 a planar flange having a mounting hole formed through an axial portion thereof, a radially expanded portion formed in a portion of the peripheral surface of the mounting hole for defining a radially inwardly projecting portion, and an annular resilient sealing member inserted in the radially
15 expanded portion; and
a pipe having an annularly expanded portion which is radially expanded for engagement with the portion of the peripheral edge of the mounting hole which is exposed on the back of the planar flange and fixing means
20 expanding radially to press the resilient sealing member against the inner wall of the radially expanded portion, and to clamp the radially inwardly projecting portion in cooperation with the annularly expanded portion.
3. An arrangement according to claim 1 or claim 2 wherein
25 the pipe is enlarged at an end thereof.
4. An arrangement according to claim 1 or claim 2, wherein

the pipe has an end portion which is partially radially expanded.

5. An arrangement according to claim 1 or claim 2 wherein the mounting hole is counterbored to a step-like form.
- 5 6. An arrangement according to claim 1 or claim 2, and having a groove in its peripheral surface to form two spaced radially inwardly directed projections.
7. An arrangement in which a pipe is attached to a flange, substantially as hereinbefore described with
10 reference to and as illustrated in Figure 1 or Figure 2 of the accompanying drawings.

Fig. 1

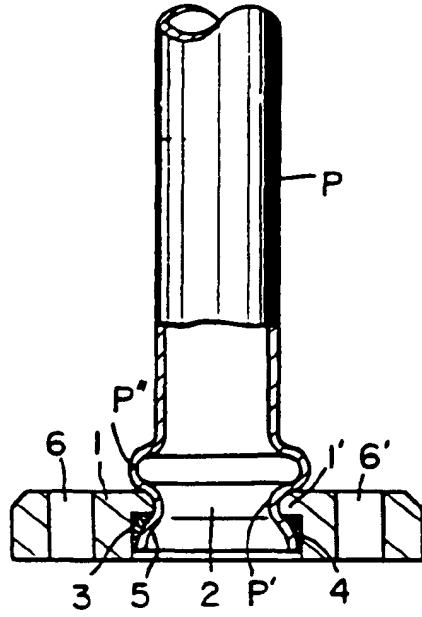

Fig. 2

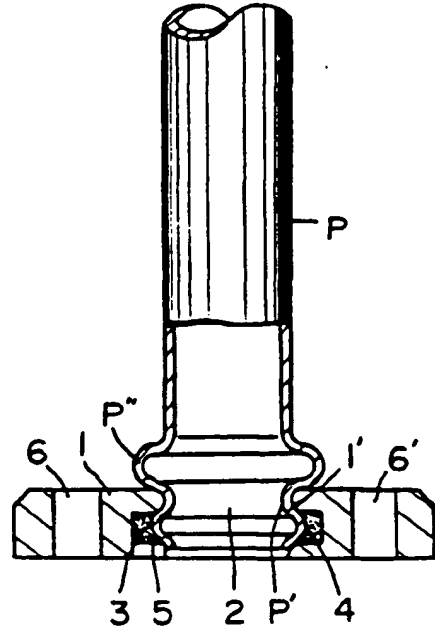

Fig. 3

PRIOR ART

